

PARKS AND RECREATION
 DESIGN AND DEVELOPMENT
 FEBRUARY 18, 2010

CITY OF BELLINGHAM
 NEIGHBORHOOD PARK SIGN
 DOUBLE SIDED (PLAN VIEW)

DRAWING
 10430.05

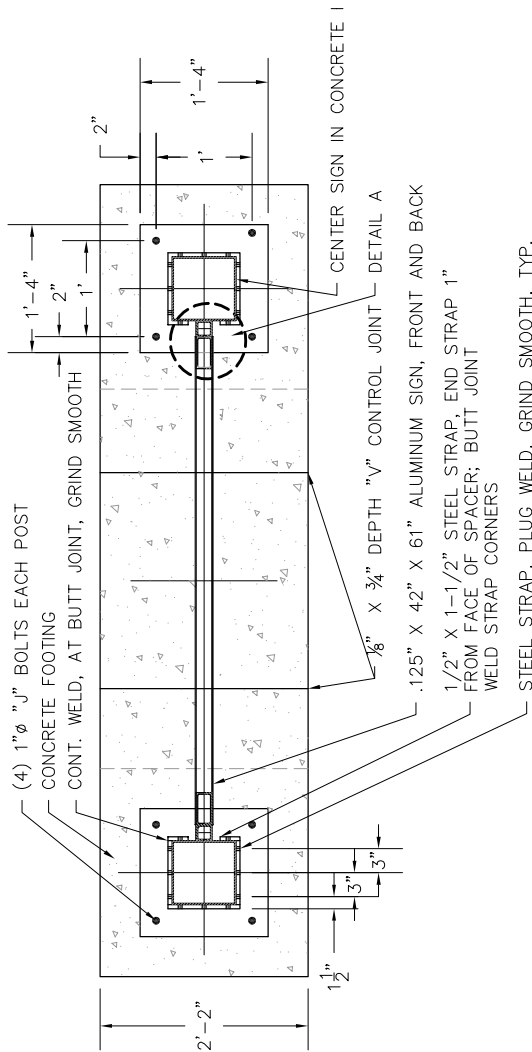

PLAN VIEW
 (SCALE 1/2" = 1'-0")

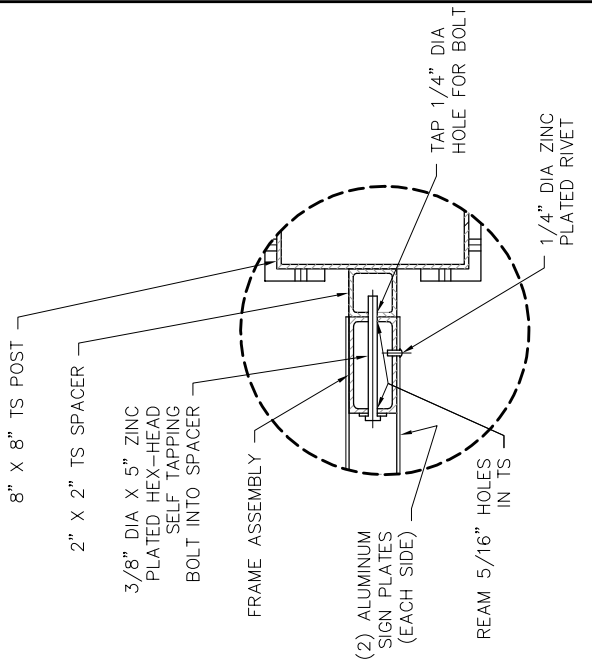

DETAIL A
 (SCALE 1 1/2" = 1'-0")

NOTES:

- A. INSTALL SIGN PLUMB AND LEVEL. SKIMCOAT BOTTOM OF BASE PLATE WITH NON-SHRINK, NON-METALLIC GROUT.
- B. ALL STEEL SHALL COMPLY WITH ASTM A500, UNLESS NOTED OTHERWISE. OWNER MAY SUBSTITUTE A36 STRUCTURAL STEEL
- C. STEEL ELEMENTS SHALL BE CONSTRUCTED IN ACCORDANCE WITH AISC CODE OF STANDARD PRACTICE.
- D. ALL STEEL SHALL BE SAND-BLASTED CLEAN, AND PRE-WASHED WITH AN IRON PHOSPHATE POWDER WASH, DRIED, PRIMED WITH ZINC PRIMER, AND POWDER COATED THE COLOR NOTED ABOVE. BAKED AT 400 DEGREES FOR NO LESS THAN 45 MINUTES, UNLESS NOTED OTHERWISE.
- E. ALL FASTENERS SHALL BE GALVANIZED OR STAINLESS STEEL.
- F. FOUNDATION DESIGN IS SHOWN FOR LEVEL GROUND ONLY WITH AN ASSUMED SOIL BEARING STRENGTH OF 1500 PSF, WHICH SHALL BE CONFIRMED BY A PROFESSIONAL ENGINEER/GEOTECHNICAL ENGINEER BEFORE COMMENCING WORK.
- G. ALL WELDS SHALL BE CONTINUOUS AND ALL AROUND. GRIND SMOOTH UNLESS OTHERWISE NOTED. WELDS SHALL BE GROUND SMOOTH BEFORE POWDER COATED.
- H. CLEAR, WEED, GRADE, MULCH, OR SEED SURROUNDING SITE AS SPECIFIED. RESTORE DISTURBED AREA IN ACCORDANCE WITH PARK STANDARDS.
- I. COLORS SHALL BE AS FOLLOWS:
 POST & BASE PLATE: MATTHEWS MP#10269 AUTO BODY PAINT W/ PRIMER, SATIN FINISH, OR MATCH DRYLAC RAL #7021 DARK GRAY, EGGSHELL FINISH
 SIGNFRAME, SPACER & ALUMINUM SIGN BODY (BODY BACK ONLY): MATTHEWS #MP14185, AUTO BODY PAINT W/ PRIMER, SATIN FINISH, OR MATCH PANTONE PMS 560C DARK GREEN, EGGSHELL FINISH.
 POST STRAP COLOR: MATTHEWS #MP04863 AUTO BODY PAINT W/ PRIMER, SATIN FINISH, OR MATCH DRYLAC RAL #3072 SM SGL TRIBO, EGGSHELL FINISH, MATCHES PANTONE 7535C
 SIGN GRAPHICS: SHALL BE PRODUCED FROM DIGITAL FILES PROVIDED BY THE OWNER AND PROVIDED TO THE CONTRACTOR FOR PRODUCTION AND ASSEMBLY, AND PLOTTED ON A TRAFFIC GRADE VINYL SELF ADHESIVE MEDIUM THAT MEETS WSDOT STANDARDS.
 THE FINISH SHALL BE NON-REFLECTIVE.