

ELEVATION

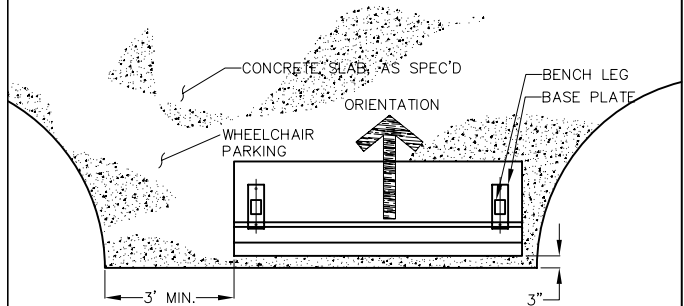

PLAN I W/ CONCRETE SLAB

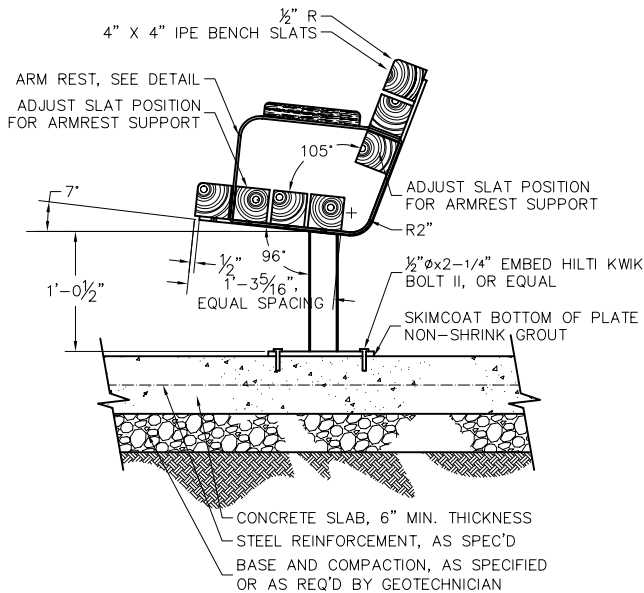

SIDE SECTION

NOTE:
SEE DRAWING PR-970B FOR
ARMREST DETAIL.

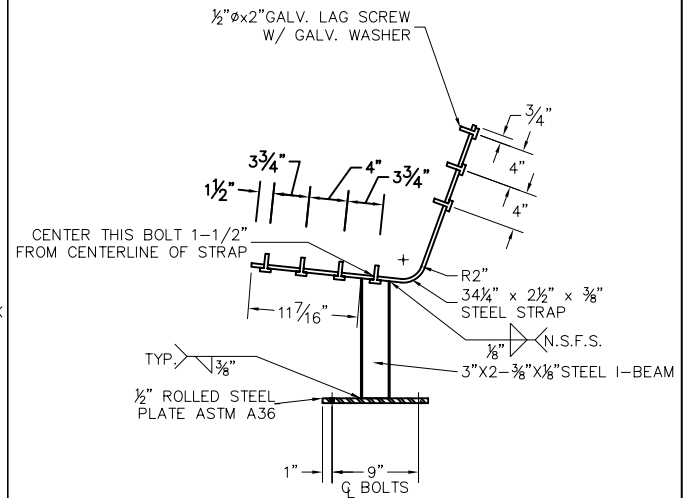

ELEVATION-STEEL

NOTES:
1. ALIGN HOLES FOR LAG SCREWS WITH THE
CENTERLINE OF STEEL STRAP AND BASE PLATE.

NOTES:

- A. ALL STEEL SHALL BE A36 STRUCTURAL UNLESS NOTED OTHERWISE.
- B. ALL STEEL SHALL BE SAND-BLASTED CLEAN, AND PRE-WASHED WITH AN IRON PHOSPHATE POWDER WASH, DRIED, PRIMED WITH ZINC PRIMER, AND POWDER COATED BLACK BAKED AT 400 DEGREES FOR NO LESS THAN 45 MINUTES, UNLESS NOTED OTHERWISE NOTED.
- C. ALL FASTENERS SHALL BE GALVANIZED.
- D. MOUNT ONLY ON CONCRETE PAVEMENT OR FOOTING.
- E. STEEL ELEMENTS SHALL BE CONSTRUCTED IN ACCORDANCE WITH AISC CODE OF STANDARD PRACTICE.
- F. CONCRETE SLAB & SUBGRADE REQUIRE SITE SPECIFIC DESIGN.

PARKS AND RECREATION
DESIGN AND DEVELOPMENT

CITY OF BELLINGHAM
STANDARD PARK BENCH
DETAIL

DRAWING
2870.01

DATE: 10/11/06